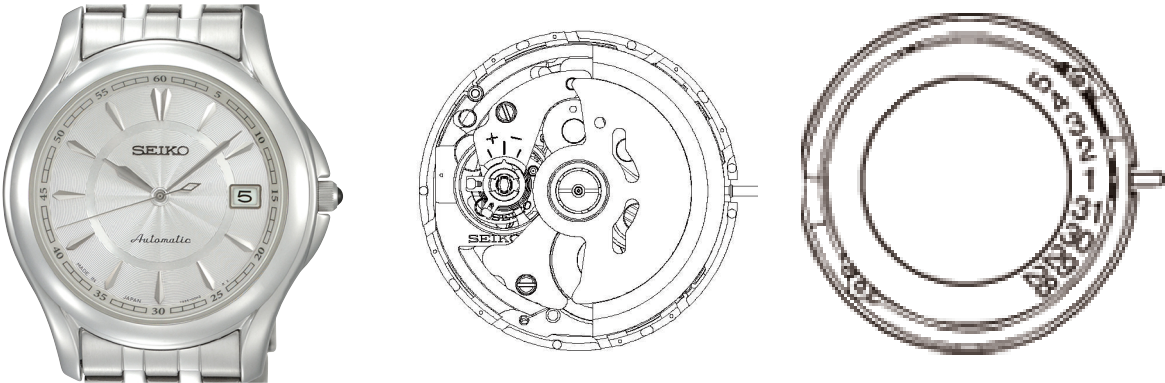

# PARTS LIST/TECHNICAL GUIDE

## Cal. 7S25C/7S35C

### [SPECIFICATIONS]

Item	Cal. No.	7S25C	7S35C
			
<ul style="list-style-type: none"> <li>• 3 hands (hour, minute and second hands)</li> <li>• Date indication</li> </ul>		<b>Movement size</b> <ul style="list-style-type: none"> <li>• Diameter      Outside: Ø 27.4 mm                          Casing:    Ø 27.0 mm</li> <li>• Height:            4.9 mm</li> </ul>	
<b>Driving system</b>		Automatic winding mechanism	
<b>Time indication</b>		<ul style="list-style-type: none"> <li>● 3 hands (hour, minute and second hands)</li> <li>● Date Indicator</li> </ul>	
<b>Additional function</b>		<ul style="list-style-type: none"> <li>● Date correction function</li> </ul>	
<b>Crown operation</b>	Normal position	-	
	1st click position	Date setting (counterclockwise)	
	2nd click position	Time setting (Hour and minute)	
<b>Vibration per hour</b>		21,600 Hz/hour (6 beats per second)	
<b>Regulation system</b>		ETACHRON system	
<b>Lift angle of the escapement</b>		53 °	
<b>Power reserve</b>		From fully wound to stoppage: Approximately 41 hours	
<b>Number of jewels</b>		21 jewels	23 jewels

SEIKO WATCH CORPORATION

# PARTS LIST

Cal. 7S25C, 7S35C

## FEATURES

SEIKO Automatic Mechanical Cal. 7S25C / 7S35C are replacement caliber of Cal. 7S25B / 7S35B.

Construction of the C series is same as B series, but using new parts. Since the size of movement is same as B series, the complete movement can be assembled into the watches which originally have the B series movement; however, as the parts are not convertible, please use the appropriate parts for each caliber.

REMARKS: Parts Differences Between B series and C series







	Parts Name	7S25B	7S35B	7S25C	7S35C
4	DATE DIAL GUARD SCREW	0016705		0012354	
5	DATE DIAL GUARD	0808300		0808310	
7	DATE JUMPER	0810030		0810183	
8	DAY-DATE CORRECTOR SETTING WHEEL	0737300		0737183	
9	HOUR WHEEL	0271483		0273182	
11	DATE DRIVING WHEEL	0802300		0802183	
12	MINUTE WHEEL AND PINION	0261006		0261183	
13	CANNON PINION	0225005		0225414	
15	SCREW FOR LOWER BRIDGE FOR 3RD WHEEL AND PINION	-	0012420	-	0012485
16	LOWER BRIDGE FOR 3RD WHEEL AND PINION	-	0436300	-	0436183
17	OSCILLATING WEIGHT	0509188	0509196	0509375	0509381
21	BALANCE COCK	0171197		0171355	
26	RATCHET WHEEL SCREW	0012919		0012919	
27	RATCHET WHEEL	0285013		0285051	
29	BARREL AND TRAIN WHEEL BRIDGE	0112400		0114178	
33	FIRST REDUCTION WHEEL	0511006		0511010	
34	PAWL LEVER	0831004		0831183	
37	BARREL COMPLETE	0201075		0201083	
41	CENTER WHEEL BRIDGE	0122300		0122302	
42	CENTER WHEEL AND PINION	0224075		0224183	
44	YOKE SPRING	0388070		0388177	
46	SETTING LEVER	0383070		0388178	
47	CLUTCH WHEEL	0282070		0282183	

# PARTS LIST

Cal. 7S25C, 7S35C

DISASSEMBLING PROCEDURES FIGS.: ① → ④⑦  
 REASSEMBLING PROCEDURES FIGS.: ④⑦ → ①

LUBRICATING: TYPES OF OIL

	AO-3 (MOEBIUS A)		OIL QUANTITY
	SEIKO WATCH OIL S-6		LIBERAL QUANTITY
	SEIKO WATCH OIL S-4		NORMAL QUANTITY
			SMALL QUANTITY

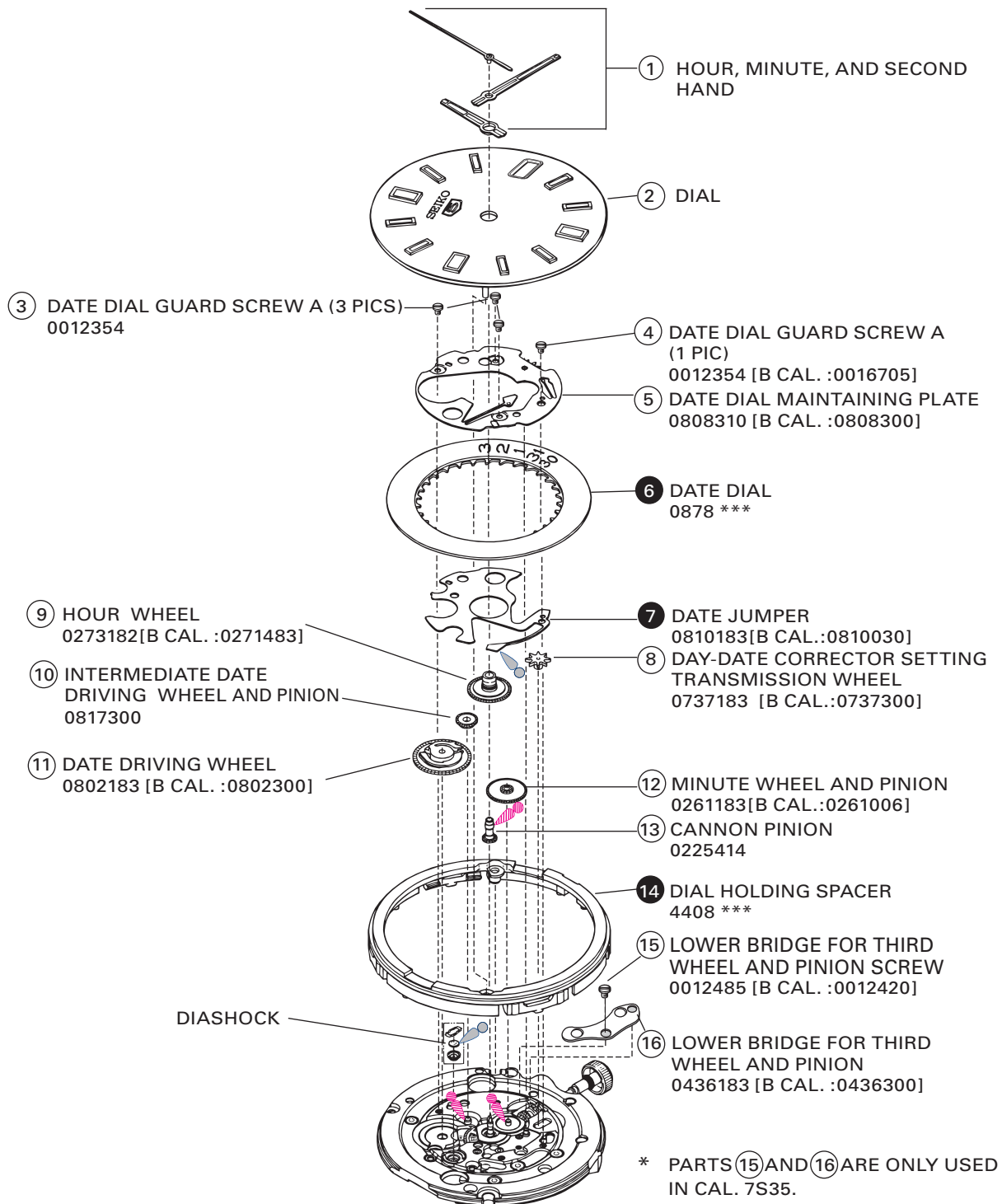

For parts ⑥ and ⑭, refer to "PARTS USED DIFFER DEPENDING ON THE CASING MODEL" on page 8.

# PARTS LIST

Cal. 7S25C, 7S35C

17 OSCILLATING WEIGHT  
0509\*\*\*

20 BALLANCE COCK SCREW  
0012420

21 BALANCE COCK  
0171355  
[B CAL. :0171197]

22-1 BALANCE COMPLETE  
(WITH STUD)  
0310197

23 PALLET COCK SCREW  
0012354

18 SECOND REDUCTION  
WHEEL AND PINION  
0012539

19 SECOND REDUCTION  
WHEEL AND PINION  
0514002

26 RATCHET WHEEL  
SCREW  
0012919

27 RATCHET WHEEL  
0285051 [B CAL. :0285013]

24 PALLET COCK  
0161300

25 PALLET FORK  
0301009

22-2 SHOCK ABSORBING  
SPRING  
0014577

22-3 SHOCK ABSORBING  
JEWEL  
0011220

22-4 HOLE JEWEL FOR  
SHOCK ABSORBER  
0014295

For parts 17 and 19, refer to "REMARKS ON DISASSEMBLING AND REASSEMBLING" on page 9.  
For parts 20, 21, and 22, refer to "HOW TO REMOVE AND INSTALL THE BALANCE STAFF" on page 10.

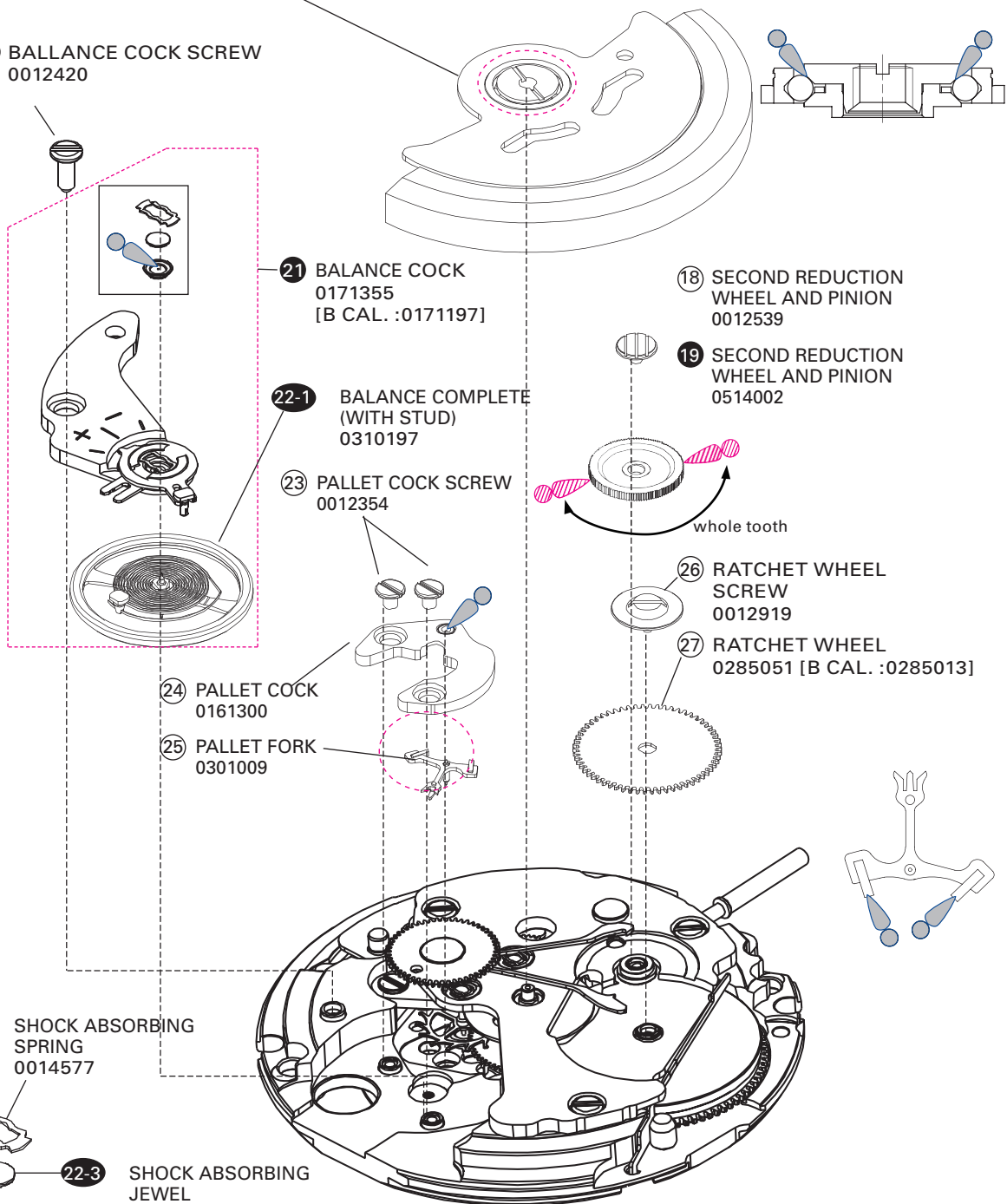

# PARTS LIST

Cal. 7S25C, 7S35C

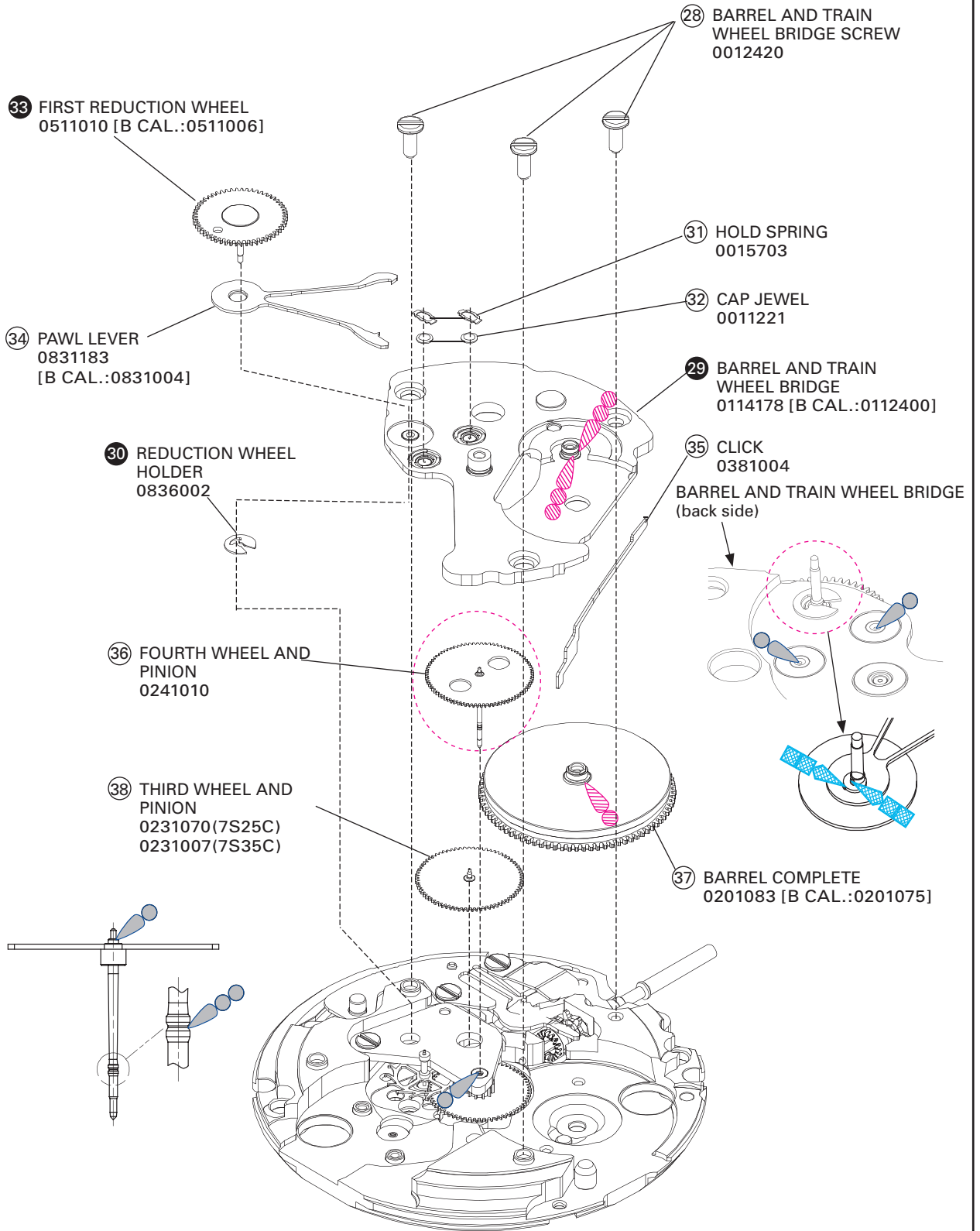

For parts **29**, **30**, and **33**, refer to "HOW TO REMOVE AND INSTALL THE BALANCE STAFF" on page 9.

# PARTS LIST

Cal. 7S25C, 7S35C

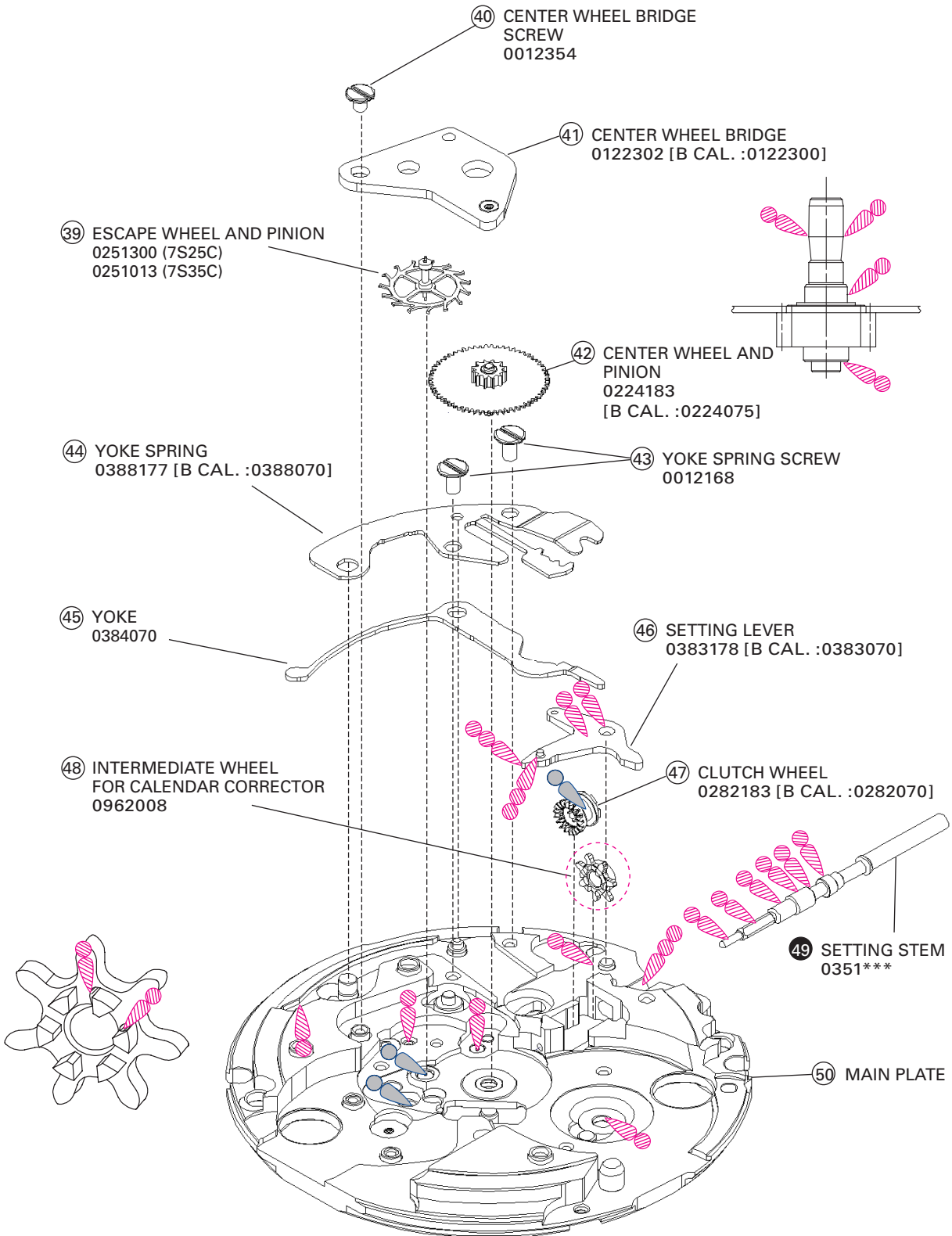



For parts 49, refer to "PARTS USED DIFFER DEPENDING ON THE CASING MODEL" on page 8.

# PARTS LIST

Cal. 7S25C, 7S35C

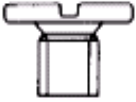
## SCREW PARTS

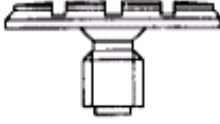
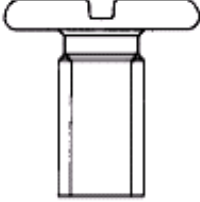
Parts code	Parts name	Parts code	Parts name
 0012 354	Center wheel bridge screw Pallet cock screw Date dial guard screw A	 0012 919	Ratchet wheel screw
 0012 420	Balance cock screw Barrel and train wheel bridge screw Lower bridge for third wheel and pinion screw	 0012 539	Second reduction wheel and pinion screw
 0012 168	Yoke spring screw		

PARTS NAME	PARTS CODE	PARTS NAME	PARTS CODE
UPPER HOLE JEWEL FRAME FOR DIASHOCK	0014 295	UPPER HOLE JEWEL FRAME FOR THIRD WHEEL AND PINION	0015 701
LOWER HOLE JEWEL FRAME FOR DIASHOCK		UPPER HOLE JEWEL FRAME FOR ESCAPE WHEEL AND PINION	0015 711
DIASHOCK UPPER FRAME	0014 573	UPPER SPRING FOR THIRD WHEEL AND PINION	0015 703
DIASHOCK LOWER FRAME	0014 574	UPPER SPRING FOR ESCAPE WHEEL AND PINION	
DIASHOCK UPPER SPRING	0014 577	REGULATOR	0341 020
DIASHOCK LOWER SPRING		STUD SUPPORT	0345 197

**PARTS USED DIFFER DEPENDING ON THE CASING MODEL**

**6 DATE DIAL**

0878 \*\*\*

\*The date dial used differs depending on the casing model. Please refer to the SEIKO WATCH PARTS CATALOGUE in order to choose corresponding parts.

**Representative DATE DIAL example**

Color of background	Color of figure	Caliber A, B	Caliber C
White	Black	0878 270	0878 208
Black	White	0878 271	0878 209

Note: The DATE DIAL used for caliber A & B is not compatible with caliber C.  
Be sure to install the corresponding DATE DIAL.

**14 DIAL HOLDING SPACER**

4408 \*\*\*

The dial holding spacer for a diver's watch has an identifying mark.

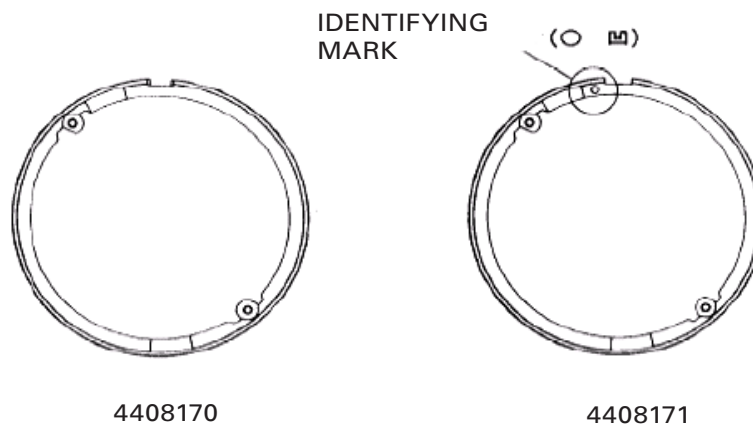

\* The dial holding spacer used differs depending on the casing model. Refer to "SEIKO Watch Parts Catalogue (SEIKO WATCH SERVICE SITE)."

**49 SETTING STEM**

0351 \*\*\*

\* The setting stem used differs depending on the casing model. Refer to "SEIKO Watch Parts Catalogue (SEIKO WATCH SERVICE SITE)."



- The following description is only applicable to 7S caliber watches.

## I. REMARKS ON DISASSEMBLING AND REASSEMBLING

### 17 OSCILLATING WEIGHT (with ball bearing)

The inside screw can be found in the inside ring of the ball bearing. Use the big screwdriver to screw sufficiently tight. When setting the oscillating weight, align the hole of the first reduction wheel with the hole of the balance cock, and then set the oscillating weight by tightening the inside screw of the inside ring of the ball bearing (refer to the right figure).

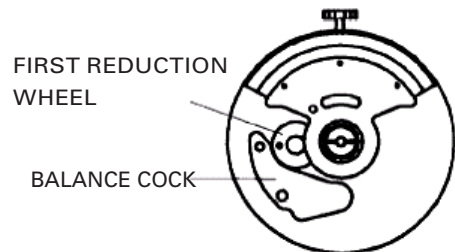

### 19 SECOND REDUCTION WHEEL AND PINION

Lubricate the second reduction wheel and pinion (refer to the right figure).

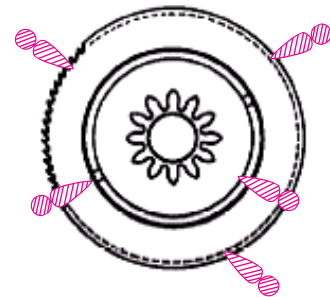

### 29 BARREL AND TRAIN WHEEL BRIDGE

Before setting the barrel and train wheel bridge, set the first reduction wheel and arbor, pawl lever, and reduction wheel holder.

### 30 REDUCTION WHEEL HOLDER

How to disassemble

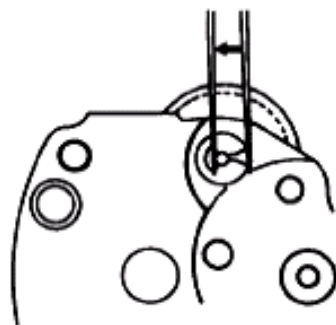

How to assemble

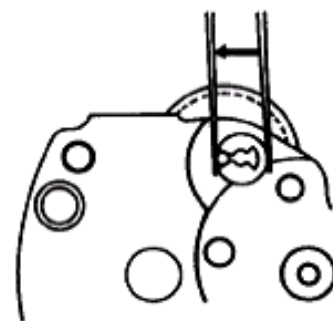

### 33 FIRST REDUCTION WHEEL

Liberaly lubricate the first reduction wheel (refer to the right figure).

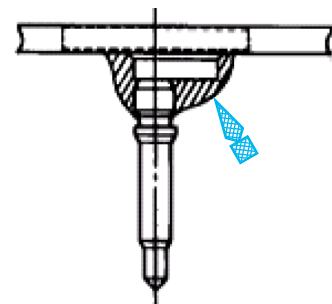

## :HOW TO REMOVE AND INSTALL THE BALANCE STAFF

### HOW TO REMOVE

1. Initial phase  
Set the balance complete with stud and balance cock to the main plate.

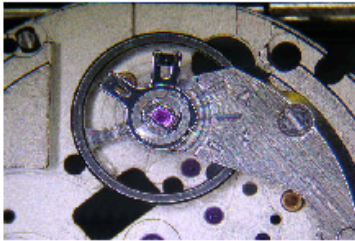

2. Move the stud support toward the balance cock until it is attached to the balance cock.  
\* When doing so, make sure that the outer end of the hairspring is not removed from the regulator arm.

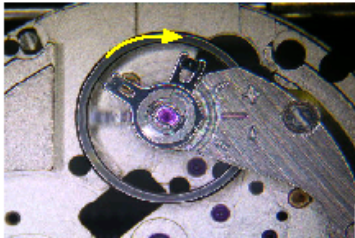

3. Using sturdy tweezers, push the stud outward from the direction of the arrow shown in the illustration until it is removed from the stud support.

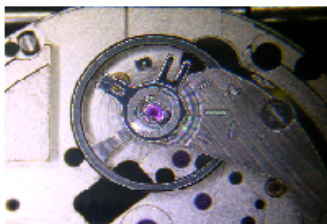
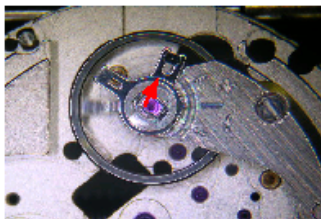

4. Remove the balance cock and replace the balance complete with stud with a new one.

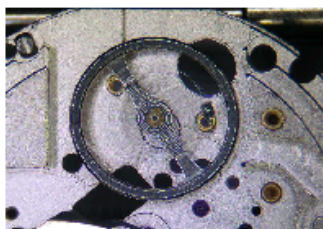

### HOW TO INSTALL

1. Initial phase  
Set a new balance complete with stud to the main plate.

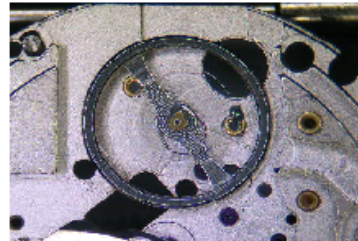

2. Set the balance cock and tighten the balance cock screw.

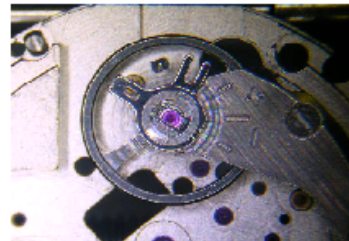

3. Temporarily set the stud to the stud support.  
Make sure that the hairspring passes outside the pin of the regulator arm.  
\* Be careful so as not to damage the hairspring.

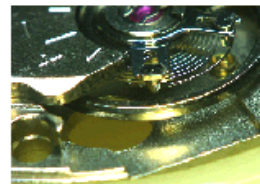
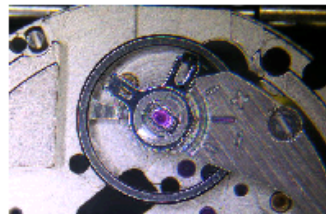

4. Using sturdy tweezers, set the stud to the stud support and press it down.

Make sure that the outer end of the hairspring passes through the regulator slot of the regulator arm.  
\* Be careful so as not to damage the hairspring.

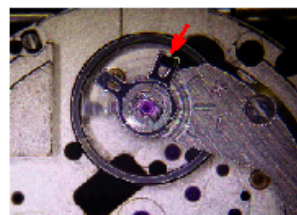

## HOW TO ADJUST THE HAIRSPRING

1. Names of the parts

- A: Stud
- B: Regulator pin
- C: Regulator arm
- D: Stud support

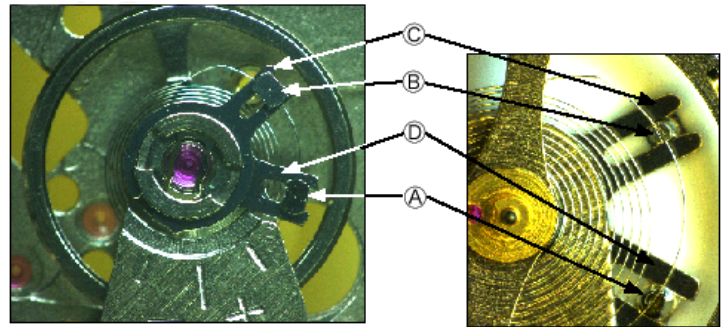

2. Rotate B to fine-tune the position of the outer end of the hairspring which passes through the regulator slot so that the hairspring makes the longest diameter.

3. Rotate A to fine-tune the position of the outer end of the hairspring so that the hairspring passes through the center of the regulator slot.

4. Rotate B to fine-tune the effective length of the hairspring which passes through the regulator slot to define adequate clearance.

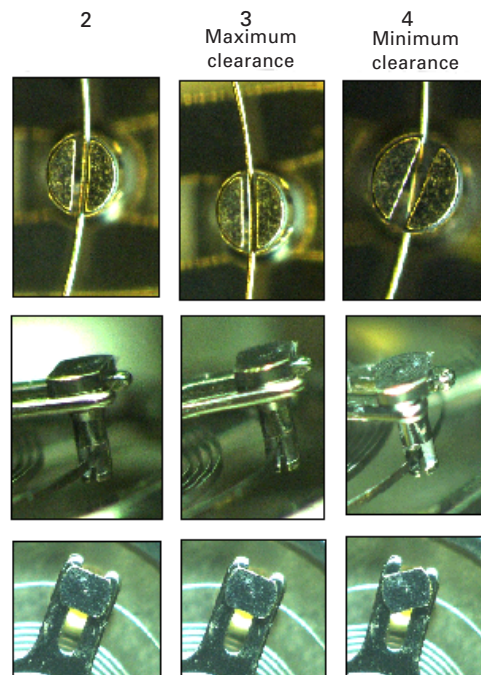

ADJUST THE POSITION OF THE HAIRSPRING SO THAT IT PASSES THROUGH THE CENTER OF THE REGULATOR SLOT.

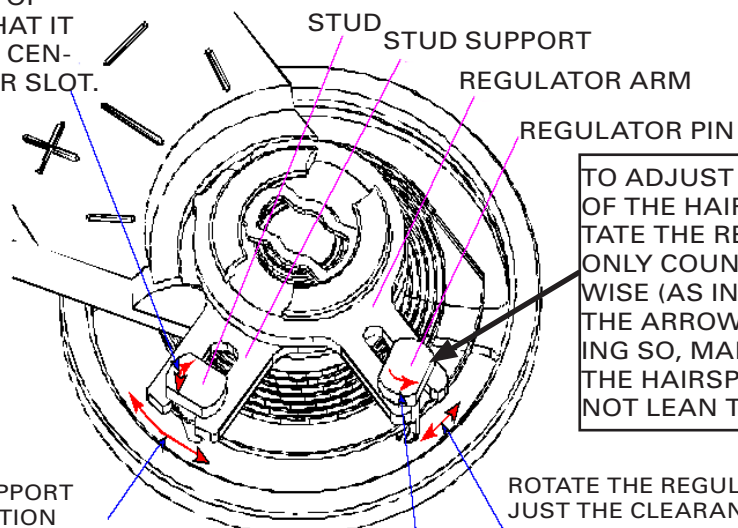

TO ADJUST THE LENGTH OF THE HAIRSPRING, ROTATE THE REGULATOR PIN ONLY COUNTERCLOCKWISE (AS INDICATED WITH THE ARROW). WHILE DOING SO, MAKE SURE THAT THE HAIRSPRING DOES NOT LEAN TO ONE SIDE.

MOVE THE STUD SUPPORT TO CORRECTLY POSITION THE ROLLER JEWEL.

ADJUST THE LOCATION OF THE REGULATOR ARM TO FINE-TUNE THE LENGTH OF THE HAIRSPRING.

ROTATE THE REGULATOR PIN TO ADJUST THE CLEARANCE TO CONTROL THE SWING ANGLE OF THE HAIRSPRING.